



emmegi

A
Aluminium
S
Steel
P
Pvc

en #2

BA 411

Assembly bench



Hard anti-friction PVC contact surfaces

01

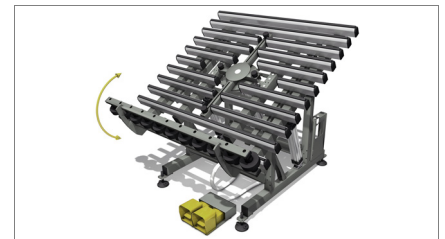

Tilting work table

02

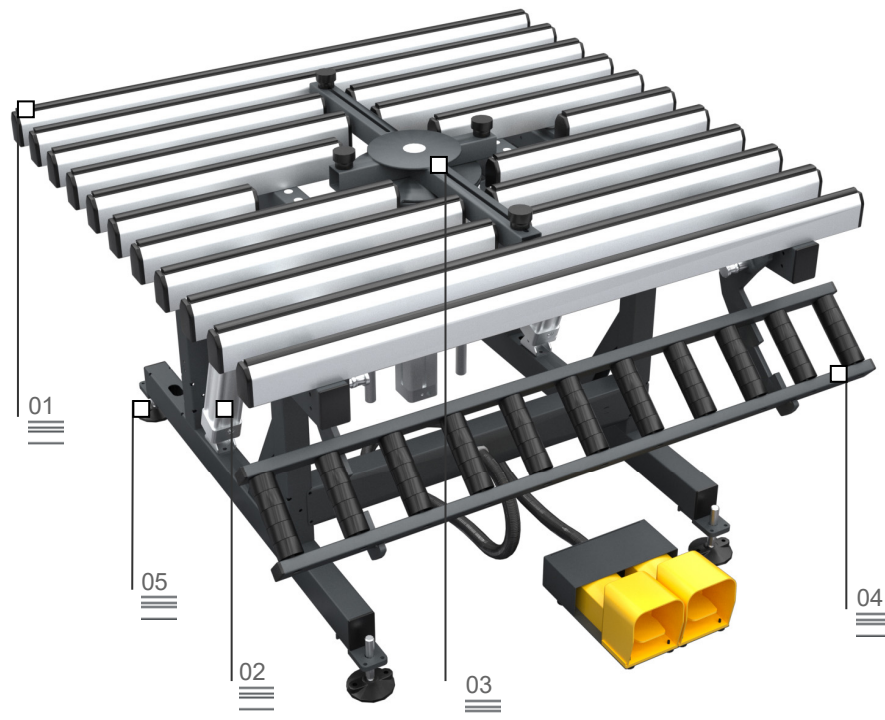

Assembly bench for glazed sashes with work table tilting from 0° (horizontal) to 85°. The drop-away roller conveyor is adjustable in height (from 170 to 460 mm) independently from the work table. The work table is adjustable from 895 to 965 mm while the feet are drilled with holes for floor anchoring. The bench is provided with a central spider clamp for hoisting and positioning the glass.

Pneumatic glazing lifting system

03



Roller conveyor

04

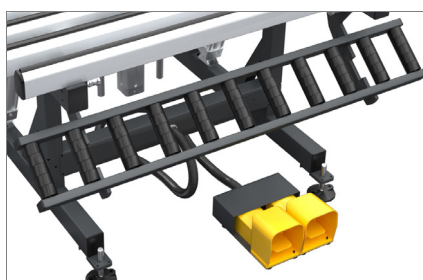

Adjustable feet

05



The images are only given for illustrative purposes

BA 411

Assembly bench

01 Hard anti-friction PVC contact surfaces

The anti-friction hard PVC contact surface protects the frame as it moves and ensures smooth movement.

02 Tilting work table

The work table can be swung with fully pneumatic movement. Using the foot switch control it can be tilted from 0° (horizontal position) to 85°.

03 Pneumatic glazing lifting system

The drop-away central spider clamp has four rubber support pads for the glazing, which may be adjusted along the axes. When the bench is in the horizontal position, the spider clamp can be lifted using the foot switch control and turned manually. A safety system prevents the spider clamp being lifted with the bench in a tilting position or the bench being tilted with the spider clamp lifted.

04 Roller conveyor.

A roller conveyor, which may be tilted manually and locked automatically (in 2 preset positions), moves the frame horizontally on rollers (mounted on a rod), which ensure smooth movement and easy handling along the production line.

05 Adjustable feet

Height-adjustable feet ensure that the work table can be set at the desired height, perfectly flush with the other products in the Dynamic Line. They also have holes for anchoring them to the floor.

TECHNICAL CHARACTERISTICS

Pneumatic tilting of work table from 0° (horizontal) to 85°	•
Hard anti-friction PVC contact surfaces	•
Pneumatic glazing lifting system	•
Roller conveyor which may be tilted manually; its height can be adjusted irrespective of the work table height	•
Feet with holes for floor mounting	•
Length (mm)	1.400
Width (mm)	1.400
Height of the work table (horizontal position) (mm)	895 ÷ 965
Max. height with glazing lifted (mm)	1.200
Weight (kg)	170
Air consumption/cycle (nL)	36

2021/01/01

www.emmegi.com

The images are only given for illustrative purposes