

Shear and stops 01

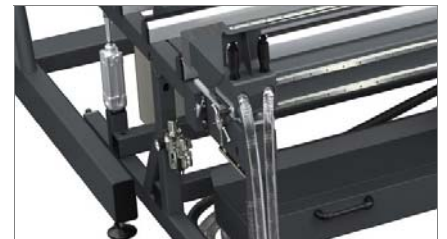

Horizontal milling unit 02

BMF 3500

Hardware assembly bench

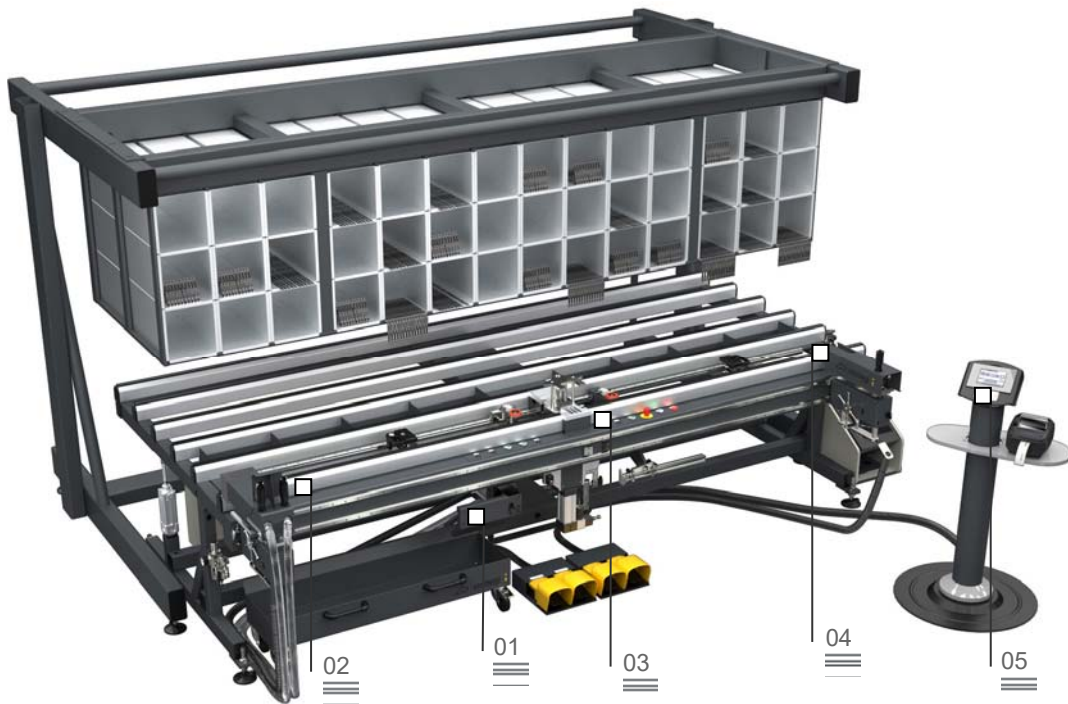

Bench for hardware assembly. The wide work bench for working large size doors and frames, and the 3 covering options (hard anti-friction PVC for aluminium, brushes for PVC, felt for wood) allow to handle any type of door/window.

The BMF 3500 is capable of hardware measuring, cutting by hydro-pneumatic shear and screwing by means of automatically fed screwing unit. Whereas the 3-spindle cremone bolt drilling unit, the cremone bolt milling unit, the hinge hole drilling unit, the scrap collecting tank, the hardware storage and the automatic glass stopper magnetic sensor measuring unit are available on request.

Three-spindle drilling unit 03

Automatic screwing unit 04

Glass stopper measuring 05



The images are only given for illustrative purposes

BMF 3500

Hardware assembly bench

01 Shear and stops

The bench is provided with shear and stops located on pneumatically powered slides with independent movement for measuring and cutting the perimeter hardware.

02 Horizontal milling unit

The cremone bolt milling unit runs on horizontal ways with positive stops for setting position of the feed stroke. Moreover a system of positionable stops allows setting the feed strokes on the three axes.

03 Three-spindle drilling unit

The drilling unit for the handle holes allows simultaneous drilling of the three holes. It can also be positioned on two axes.

04 Automatic screwing unit

The screwing unit with automatic feed runs on horizontal slideways and is provided with a laser positioning system. It also allows manual insertion of non-standard screws

05 Glass stopper measuring

This device provides the exact measurement of the door glass stopper being processed. The position of the internal locking stops is detected by 2 readers. Then the parameter is processed by the PLC which prints the barcode label to be applied onto the door with the printer.

WORK BENCHES	
Hard anti-friction PVC contact surface	•
Pneumatic tilting of work table from 0° (horizontal) to 12°	•
Adjustable work table height (mm)	875 + 925
WORKPIECE LOCKING	
Self-centring pneumatic clamping system	•
Clamp opening (mm)	270 + 2,870
CHARACTERISTICS	
Automatic measurement of the hardware	•
Horizontal milling unit running on guides with positive stops for setting position of feed stroke.	○
Three-spindle drilling unit for drilling handle holes.	○
Automatic screwing unit on horizontal guide with laser positioning system	•
Set of outer right and left adjustable stops with references for cremone bolt centre.	○
Hydro-pneumatic shear	•
Drilling unit for holes and hinges	○
Scrap container	○
42-compartment hardware storage	○
Automatic glass stopper measuring	○
Length (mm)	3,540
Width (mm)	1,960
Weight (basic/full optional version) (kg)	500 / 1,600
Air consumption (NI/min)	870
Installed power (kW)	0.5 / 3.65
Load capacity (kg)	240