



emmegi

Aluminium

Steel

Pvc

en #3

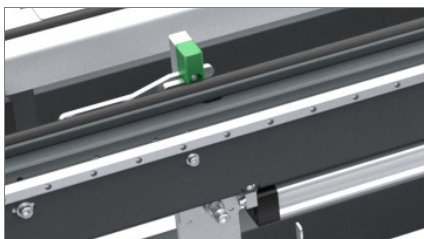

Clamping system

01



Hard anti-friction PVC contact surface

02

Fit MA

Hardware assembly bench

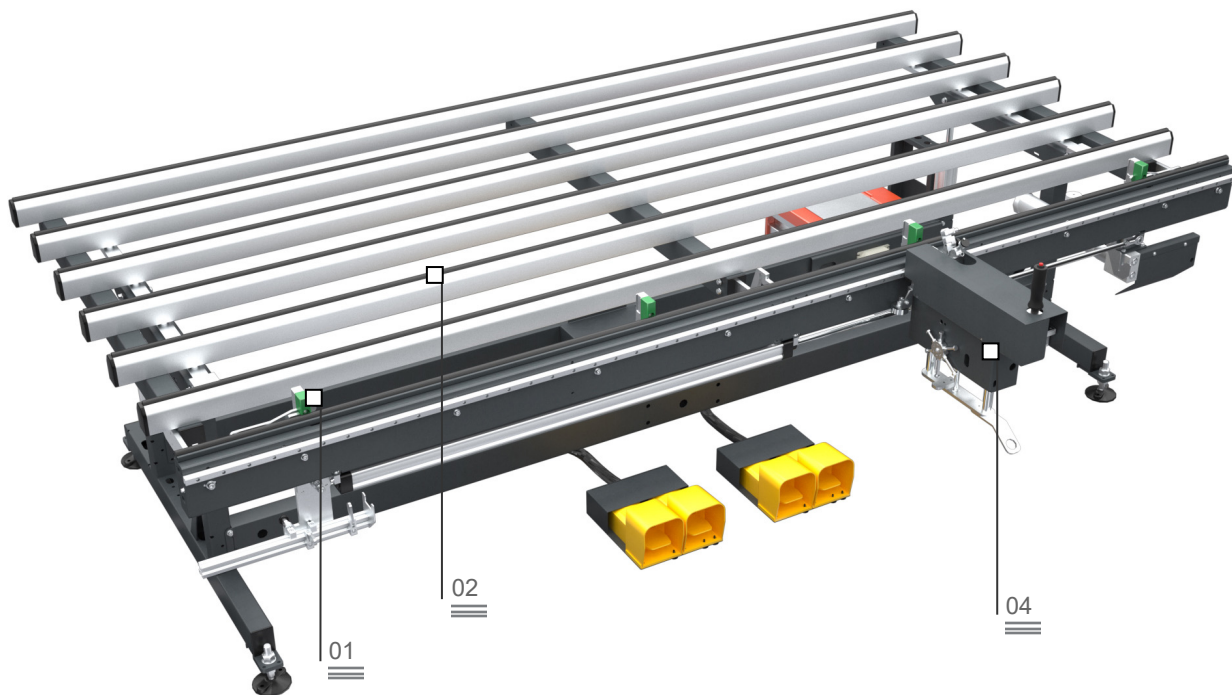

Correct flow of materials, whether semi-finished products or parts in the assembly phase or finished products, plays an important role in rationalizing and optimizing the production cycle. The Emmegi Logistics line offers companies a concrete solution to all storage, handling and assembly problems.

Fit MA is an assembly bench for fitting perimeter band-sawed hardware on aluminium, wood and PVC sashes.

A system of drop-away clamps grips the sash. The bench is equipped with an automatically fed screwing unit.

Pneumatic work table tilting

03

Automatic screwing unit

04

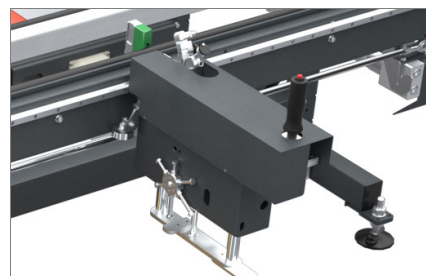

The images are only given for illustrative purposes

Fit MA

Hardware assembly bench

01

Clamping system

A system of drop-away clamps under the work table allows centered clamping of the door or window.

02

Hard anti-friction PVC contact surface

The Hard anti-friction PVC contact surface ensures smooth movement and easy handling of the frame.

03

Pneumatic work table tilting

Thanks to the foot switch control the work table can be tilted with pneumatic movement from 0° (horizontal) to 12° for facilitating fitting of the hardware.

04

Automatic screwing unit

The screwing unit with automatic feed runs on horizontal slideways.

WORK TABLES

Pneumatic tilting of the work table from 0° (horizontal) to 12°

•

Adjustable work table height (mm)

875 ~ 925

WORKPIECE CLAMPING

Clamp opening (mm)

290 ~ 2.840

Adjustable clamping force, max.

740 N

Gripping system with self-centering clamping frame and drop-away bars

•

CONTACT SURFACE

Hard anti friction PVC contact surface

•

MISCELLANEOUS

Characteristic "A": automatic screwing unit running on horizontal slideways

•

Characteristic "C": band-sawing of perimeter hardware with automatic stop gauge

○

Load capacity (kg)

1960

Air consumption (NI/min)

870

Installed power (kW)

0,35

- included
- available

2021/01/01

www.emmegi.com

The images are only given for illustrative purposes