

Phantomatic M3

Machining centre

Clamps 01

01

Electrospindle 02

02



CNC machining centre, with 3 controlled axes; the spindle has an automatic tool slewing system on 3 fixed positions that allows processing on 3 sides of the workpiece.

Designed for machining bars or parts made of aluminium, PVC, light alloys in general or steel up to 2 mm. It is provided with a manual tool storage magazine with 9 places to which one or two additional automatic storage magazines with 4 places can be added at the sides of the machine.

The workpieces is positioned by a pneumatic stop positioned at the left side of the machine, and is blocked by 4 strong clamps that are positioned by the slider on the X axis. Adding a second optional stop on the right side, the machine may perform extended machining of bars up to twice the work capacity.

Moreover it is equipped with a movable work plane for easier workpiece loading/unloading; this also allows considerable increase in the machinable section.

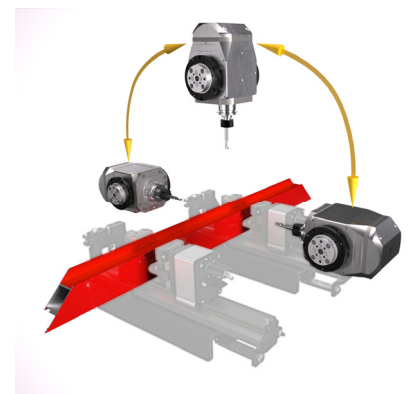

Automatic tool storage system (optional) 03

03

Operator interface 04

04

Pneumatic stops 05

05

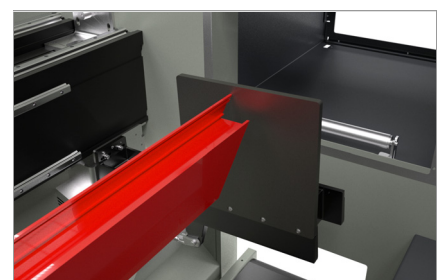
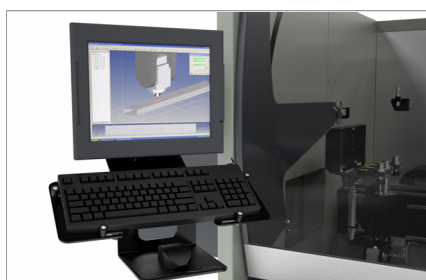

Phantomatic M3

Machining centre

01 Clamps

Depending on the length of the workpiece and the processes to be carried out, the machine software is able to safely determine the positioning quota of every clamp unit. The automatic positioner allows every clamp unit to be coupled and moved by moving the slider. This operation is implemented at maximum speed and precision, thereby avoiding long times and risks of collision and making the machine easy to use even by operators with less experience. The mobile work table facilitates the piece loading/unloading operation and significantly increases the workable section.

02 Electrospindle

The 4 kW electrospindle in S1 can reach 20,000 rpm. The movement of the electrospindle along axis A allows rotations to -90° and $+90^\circ$ to be implemented, thereby allowing the profile to be processed on 3 sides, without having to reposition it. Rotation is implemented in 3 fixed positions. It can be used on profiles made of aluminium, PVC and light wood and can process extruded steel that is 2 mm thick.

03 Automatic tool storage system (optional)

The tool holder storage system can host 9 tool holders. It is manual and rollaway and is positioned on board the machine for practical control by the operator. As an option, the machine can be equipped with one or two additional automatic storage systems at the sides of the cabin. Each of them can host 4 tool holders with respective tools adjusted as desired by the operator.

04 Operator interface

The new HMI version with a suspended interface allows the operator to see the screen from any position thanks to the possibility of rotating the monitor on the vertical axis. The operator interface has a 15" touch screen display with all USB connections necessary to remotely interface with PC and NC. It has a push button panel, mouse and keyboard. It is also set up for the connection of a barcode reader. IT IS equipped with a front USB for data exchange.

05 Pneumatic stops

In the machine there are robust stops that allow the bar reference; one is placed on the left side (standard) and on the right side (optional). Every stop is activated by a pneumatic cylinder is retractable and is automatically selected by the machine software according to the processing to be performed. The advantages of the double stop include the possibility of repositioning the bar or the workpiece and process particularly long profiles



Single piece mode

AXES TRAVEL	
X AXIS (longitudinal) (mm)	3.000
Y AXIS (transversal) (mm)	274
Z AXIS (vertical) (mm)	390
Automatic positioning on 3 fixed positions and manual on intermediate positions	-90° 0 $+90^\circ$
POSITIONING SPEED	
X AXIS (m/min)	56
Y AXIS (m/min)	22
Z AXIS (m/min)	22
ELECTROSPINDLE	
Maximum power in S1 (kW)	4
Maximum speed (1/min)	20.000
Tool connector cone	HSK-50F
Automatic tool holder hook	•
Liquid cooling	•
TOOL STORAGE SYSTEM	
Manual tool storage system maximum number	9
Automatic tool storage system with 4 places (left)	○
Secondary automatic tool storage system with 4 places (right)	○
Loadable blade diameter into the storage system (mm)	80
TAPPING CAPACITY (with tap, on aluminium through hole)	
With compensator	M5
With helical Interpolation	•
PROFILE POSITIONING	
LEFT stop pneumatically moved workpiece reference	•
RIGHT stop pneumatically moved workpiece reference	○
WORKPIECE LOCKING	
Clamps standard number	4
Automatic clamp positioning through X axis	•
SAFETY DEVICES AND GUARDS	
Full guard cabin	•
Side tunnels	○