



Module Bench

Assembly bench



Drop-away roller conveyor 01



Extension 02

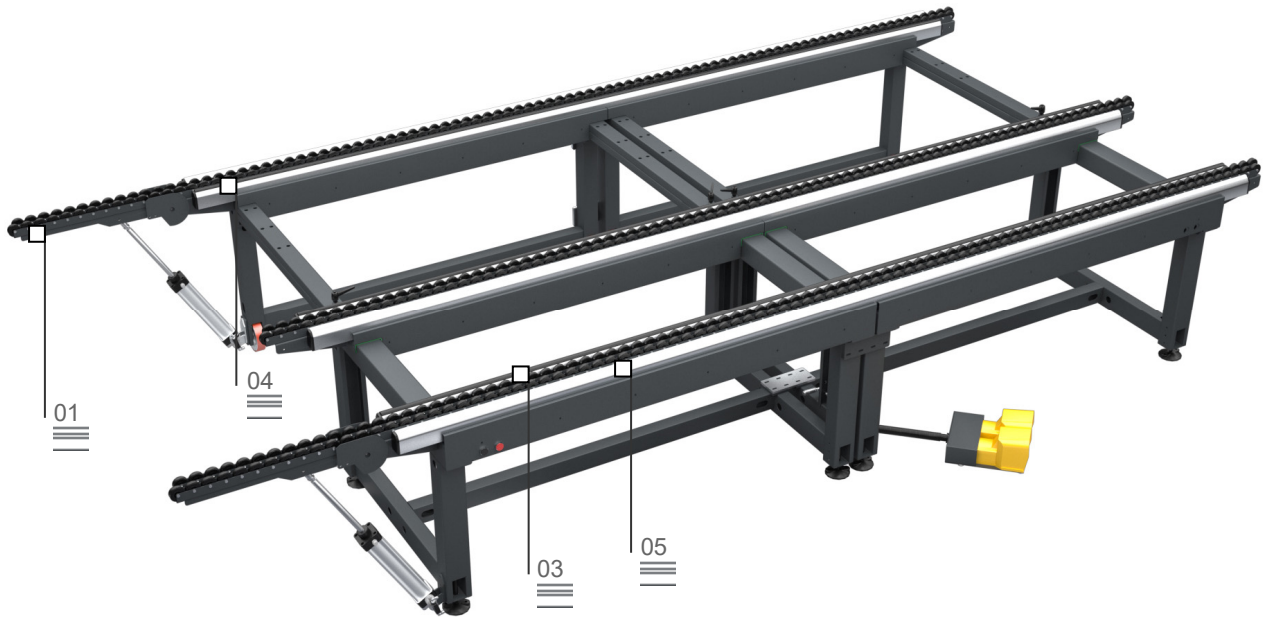

Large size and extendible modular bench for assembling of windows and curtain wall frames. It features 3 distinct work tables: one of soft PVC for assembly operations, one of anti-friction hard PVC for the rotation and a roller conveyor for in-line movements.

Roller conveyor 03



Soft anti-slip PVC work surface 04



Hard anti-friction PVC work surface 05



The images are only given for illustrative purposes

Module Bench

Assembly bench

01

Drop-away roller conveyor

Push-button operated, the drop-away roller conveyor allows you to set the bench into the production line; moreover it can be dropped-away so that it does not interfere with the operator's movement during assembly operations.

02

Extension

Module Bench can be extended from 1,300 mm to 2,500 mm. It has a tightening lever that allows you to set it in any position, thus making this bench highly versatile. Moreover, the central support can be positioned manually for processing small frames.

03

Roller conveyor

The roller conveyor lets you transfer the workpiece along the assembly line with little effort by the operator.

04

Soft anti-slip PVC work surface

The work surface of soft PVC ensures a high coefficient of friction during assembly.

05

Hard anti-friction PVC work surface

The polyethylene work surface ensures a low coefficient of friction during rotation of the workpiece.

WORK SURFACES

Drop-away roller conveyor, right or left	•
Soft anti-slip PVC work surface - length (mm)	4.000
Hard anti-friction PVC work surface - length (mm)	4.000
Roller conveyor - length (mm)	4.000
Overall length of fully raised roller conveyor (mm)	4.600
Drop-away roller conveyor - length (mm)	600

CHARACTERISTICS

Extension in width (mm) with moveable central support (mm)	1.300 ÷ 2.500
Height (mm)	900
Air consumption (NI/min)	50
Weight (kg)	550